

# RVS-AXO

## Digital Soft Starter with internal Bypass

### 3-150A, 220/400 / 500V





## **RVS-AXO Instruction Manual**

### **1. TABLE OF CONTENT**

<b>1.</b>	<b>Table of Content .....</b>	<b>3</b>
<b>2.</b>	<b>Safety &amp; Warnings .....</b>	<b>5</b>
2.1	Safety .....	5
2.2	Warnings .....	5
<b>3.</b>	<b>Technical Data .....</b>	<b>6</b>
3.1	Introduction.....	6
3.2	Technical specifications.....	6
3.3	Functions.....	7
3.4	Protections.....	7
3.5	Rating and frames sizes .....	7
3.6	Starter Selection .....	8
3.7	Models and motor power ratings .....	8
3.8	Ordering Information .....	9
<b>4.</b>	<b>RECOMMENDED WIRING SCHEMES.....</b>	<b>10</b>
4.1	Typical wiring diagram.....	10
4.2	Control Supply (Terminals 1,2) .....	11
4.3	Start / Stop input (Terminal 3) .....	11
4.4	Run contact (Terminals 4, 5).....	11
4.5	Fault contact (Terminals 6, 7) .....	11
<b>5.</b>	<b>DIMENSIONS.....</b>	<b>12</b>
<b>6.</b>	<b>INSTALLATION.....</b>	<b>14</b>
6.1	Prior to Installation .....	14
6.2	Mounting.....	14
6.3	Power wiring instructions .....	14
<b>7.</b>	<b>Operation Interface .....</b>	<b>15</b>
7.1	Control .....	15
7.2	Control terminals .....	15
7.3	User interface and LEDs status description .....	16
7.4	LEDs status description .....	16
7.5	Trouble shooting .....	17
<b>8.</b>	<b>PROTECTION SETTINGS .....</b>	<b>18</b>
8.1	Protections list.....	18
8.2	Overload trip time .....	19
<b>9.</b>	<b>Setting parameters.....</b>	<b>20</b>
<b>10.</b>	<b>SERIAL LINK PROTOCOL INTRODUCTION .....</b>	<b>21</b>
10.1	Features .....	21
10.2	BASIC STRUCTURE OF THE SERIAL LINK FRAME.....	22
10.3	SYNC (Silent Interval).....	22
10.4	SERIAL LINK NO. (SLAVE ADDRESS) .....	22
10.5	FUNCTION .....	22
10.6	LIST OF FUNCTIONS SUPPORTED BY THE RVS-AXO.....	23

10.7 DATA .....	23
10.8 CRC.....	23
10.9 ACTUAL DATA (Input registers).....	24
10.10 Faults list.....	25
Example 1 .....	25
Note: \$XX indicates Hexadecimal byte.....	25
10.11 SETTING PARAMETERS (Holding registers) .....	26
Example 2: .....	29
Example 3: .....	29
Example 4: .....	30
10.12 DISCRETE COMMANDS (@0...@7 coils).....	31
Example 5 - Force Single Coil:.....	31
10.13 DISCRETE HARDWIRED INPUTS Reading.....	32
Example 6: .....	32
10.14 DIAGNOSTICS.....	33
10.15 EXCEPTION RESPONSES .....	34
10.16 Exception Code Response Frame .....	34
10.17 Exception Codes supported by the RVS-AXO.....	35

## 2. SAFETY & WARNINGS

### 2.1 Safety

	1	Read this manual carefully before operating the equipment and follow its instructions.
	2	Installation, operation and maintenance should be in strict accordance with this manual, national codes and good practice.
	3	Installation or operation not performed in strict accordance with these instructions will void manufacturer's warranty.
	4	Disconnect all power inputs before servicing the soft-starter and/or the motor.
	5	After installation, check and verify that no parts (bolts, washers, etc.) have fallen into the starter.
	6	During shipping, the soft-starter might have been roughly handled, therefore, it is recommended to initialize the soft-starter by connecting supply voltage prior to operating the soft-starter with a motor

### 2.2 Warnings

	1	Internal components and PCBs are at mains potential when the RVS-AXO is connected to mains. This voltage is extremely dangerous and will cause death or severe injury if contacted.
	2	When RVS-AXO is connected to mains, even if start command has not been issued and motor is stopped, full voltage may appear on starter's output and motor's terminals.  Therefore, for isolation purposes it is required to connect an isolation device upstream to the RVS-AXO.
	3	The starter must be properly grounded to ensure correct operation, safety and to prevent damage.
	4	Check that Power Factor capacitors are not connected to the output side of the soft starter.
	5	Do not interchange line and load connections

**The company reserves the right to make any improvements or modifications to its products without prior notice.**

### 3. TECHNICAL DATA

#### 3.1 Introduction

The RVS-AXO is a starter designed for use with standard three-phase, three-wire, squirrel cage, induction motors.

It provides the best method of reducing current during motor starting.

The RVS-AXO starts the motor by supplying a slowly increasing voltage, providing soft start and smooth acceleration, while drawing the minimum current necessary to start the motor.

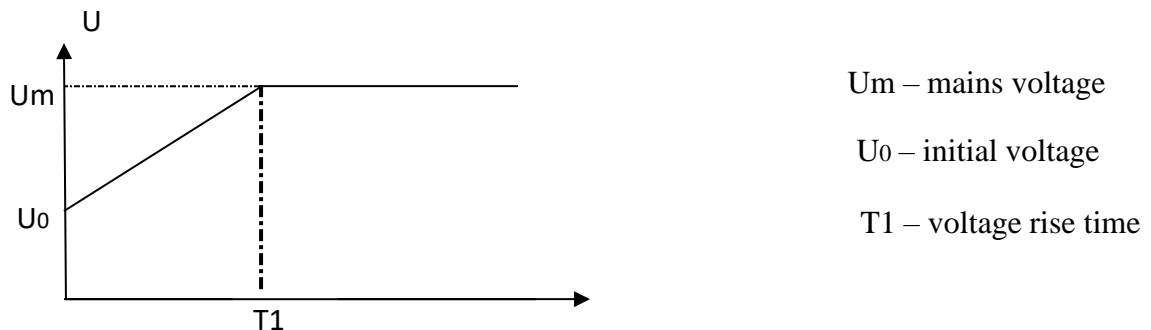

The RVS-AXO is equipped with internal by-pass controlled by its micro-controller. The bypass closes after the end of the starting process, thus reducing heating and saving power.

#### 3.2 Technical specifications

- Rated Main Voltage: 220-500VAC, 50/60Hz, +10% -15%.
- Control Voltage: 100~240VAC.
- Rated Main Current: 3A.....150A.
- Initial voltage: 30%~70%.
- Acceleration time: 1~30 Sec.
- Deceleration Time: 0~30 Sec.
- Thermal capability: 3xIn 7 sec, valid for 50 % on time and 50 % off time.
- Numbers of start per hour: 6, 7-10 (light load or no-load)
- Operation Environmental temperature: 0 °C to + 40 °C (32 °F to 122 °F).
- Store temperature: -40 °C to + 70 °C (-40 °F to 158 °F).
- Maximum altitude: 1000m (3280 ft).
- Ingress Protection class: IP21.
- 1 start/stop digital input.
- Communication interface RS485/ MODBUS /RTU.
- 2 Output relays (run and fault).

### 3.3 Functions

- Start/stop ramp and initial voltage set by 3 different built-in potentiometers.
- Bypass relay built-in, No need for extra contactor.
- Voltage ramp with current limit mode. External  $\Delta$  , Y Wiring mode.
- Three phase currents, average current , statistical data and last 10 faults may be obtain via communication.

### 3.4 Protections

- Overcurrent.
- Undercurrent.
- Overload classes 10A,10,20 and 30.
- Three-phase current unbalance.
- Phase missing/ No voltage .
- Phase sequence.
- SCR Overheating.

### 3.5 Rating and frames sizes

Frame	Starter type	Starter FLC [A]	Dimensions HxWxD [mm]	Weight [Kg]
A	RVS-AXO 3	3	175*92*95	0.8
	RVS-AXO 4.5	4.5	175*92*95	0.8
	RVS-AXO 7.5	7.5	175*92*95	0.8
	RVS-AXO 11	11	175*92*95	0.8
B	RVS-AXO 15	15	200*108*105	1
	RVS-AXO 22	22	200*108*105	1
C	RVS-AXO 30	30	222*125*132	2
	RVS-AXO 37	37	222*125*132	2
	RVS-AXO 45	45	222*125*132	2
	RVS-AXO 60	60	222*125*132	2
	RVS-AXO 75	75	222*125*132	2
D	RVS-AXO 90	90	310*155*160	5
	RVS-AXO 110	110	310*155*160	5.2
	RVS-AXO 150	150	310*155*160	5.2

### 3.6 Starter Selection

Select RVS-AXO according to motor's Full Load Ampere (FLA) - as indicated on its nameplate (even if the motor will not be fully loaded).

RVS-AXO is designed to operate under the following maximum conditions:

Ambient temperature °C	Starting current (A)	Acceleration time (sec)	Starts per hour
40	3 * I <sub>n</sub>	7	6

When operating under ambient temperature higher than 40 °C, RVS-AXO nominal current decreases by 0.8% / 1°C.

When operating at altitude above 1000m, RVS-AXO nominal current decreases by 1% / 150m.

### 3.7 Models and motor power ratings

Model	Motor power rating			Rated current I <sub>e</sub> A	Frame F	Weight kg
	220V P/kW	400V P/kW	500V P/kW			
	RVS-AXO 3	0.75	1.5	2.2	3	A
RVS-AXO 4.5	1.1	2.2	3.7	4.5	A	0.8
RVS-AXO 7.5	1.5	3.7	5.5	7.5	A	0.8
RVS-AXO 11	2.2	5.5	7.5	11	A	0.8
RVS-AXO 15	3.7	7.5	11	15	B	1
RVS-AXO 22	5.5	11	15	22	B	1
RVS-AXO 30	7.5	15	18.5	30	C	2
RVS-AXO 37	11	18.5	22	37	C	2
RVS-AXO 45	15	22	30	45	C	2
RVS-AXO 60	18.5	30	37	60	C	2
RVS-AXO 75	22	37	45	75	C	2
RVS-AXO 90	25	45	55	90	D	5
RVS-AXO 110	30	55	75	110	D	5.2
RVS-AXO 150	37	75	90	150	D	5.2



### 3.8 Ordering Information

<b>RVS-AXO</b>	<b>3-</b>	<b>400-</b>	<b>230-</b>	<b>3M-</b>	<b>S</b>
	Full load Current	Mains Voltage	Control Voltage	Options	Front Panel
<b>Full load Current</b>					
<b>Specify</b>	<b>Description</b>				
Starter's FLC [A]	3, 4.5, 7.5, 11, 15, 22, 30, 37, 45, 60, 75,90,110,150				
<b>Mains Voltage</b>					
<b>Specify</b>	<b>Description</b>				
220	220 VAC, 50/60Hz , +10% -15%				
400	400 VAC, 50/60Hz , +10% -15%				
500	500 VAC, 50/60Hz , +10% -15%				
<b>Control Voltage</b>					
<b>Specify</b>	<b>Description</b>				
230	100-240VAC, 50/60Hz , +10% -15%				
<b>Options</b>					
<b>Specify</b>	<b>Description</b>				
3M	Communication RS-485 Board (MODBUS)				
<b>Front Panel</b>					
<b>Specify</b>	<b>Description</b>				
S	Standard lexan				

#### Example for selection

RVS-AXO mains voltage 400V, rated 75A: **RVS-AXO 75-400-230-3M-S**

#### Example for RVS-AXO sticker



## 4. RECOMMENDED WIRING SCHEMES

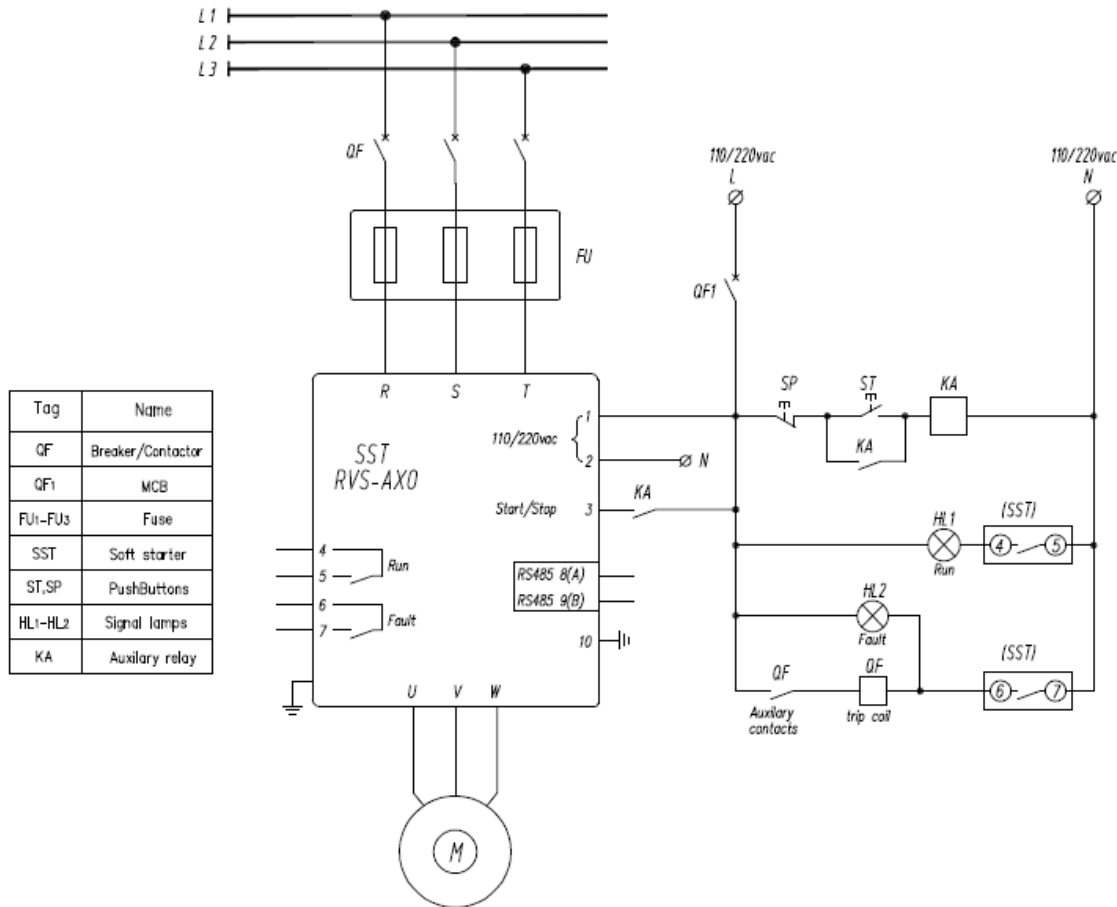

### 4.1 Typical wiring diagram

#### Notes:

- (1) - Use fuses for type 2 coordination.
- (2) – Use a maintained contact to start the motor. Open the contact to soft stop/stop the motor.

#### WARNINGS!

When mains voltage is connected to the soft starter, full voltage may appear on the starter load terminals.

Therefore, for isolation purposes, it is necessary to connect an isolating device before the starter.

Power factor correction capacitors **must not** be installed on starters load side. When required, install capacitors on starter's line side.

When the line contactor QL is operated by a maintained contact, in case of Mains failure, the motor will be automatically restarted upon voltage restoration!

Do not use the Fault contact to trip an upstream contactor!

When the Fault contact trips the upstream contactor, Mains voltage will be disconnected, thus resetting the starter and the motor will restart instantaneously upon voltage restoration!

**Notes:**

- (3) – Circuit breaker provides IEC type 1 coordination. Use fuses for IEC type 2 coordination. Refer to table below.

Model	SCR $i^2 * t(A^2 * sec)$	Fuse value
RVS-AXO 3	270	10A
RVS-AXO 4.5	610	16A
RVS-AXO 7.5	1,700	25A
RVS-AXO 11	3,630	32A
RVS-AXO 15	6,750	32A
RVS-AXO 22	14,250	50A
RVS-AXO 30	27,000	63A
RVS-AXO 37	41,070	100A
RVS-AXO 45	60,750	125A
RVS-AXO 60	108,000	125A
RVS-AXO 75	168,750	200A
RVS-AXO 90	40,000	315A
RVS-AXO 110	60,000	315A
RVS-AXO 150	100,000	400A

#### 4.2 Control Supply (Terminals 1,2)

100-240VAC, 50/60Hz is required to power the electronic circuitry and the bypass.

#### 4.3 Start / Stop input (Terminal 3)

Close contact between 1 and 3 to soft start the motor.

To stop the motor open the contact. If deceleration time is set to 0 Sec, the motor stops in a minimum time.

Commands to start / stop can be sent by Modbus communication channel as well.

#### 4.4 Run contact (Terminals 4, 5)

It is a voltage free, N.O. 5A, 250VAC contact.

It is possible by Modbus communication channel to select two options. See page 27.

Option 1 : Contact energizes during start and remain during run and soft stop.

This is a factory setting.

Option 2: Contact indicates status of internal bypass.

#### 4.5 Fault contact (Terminals 6, 7)

It is a voltage free, N.O. 5A, 250VAC contact.

Contact closes when soft starter trips. For reset, the control voltage has to be disconnected and then connected.

Trip can be reset by Modbus channel as well.

## 5. DIMENSIONS

### Frame A

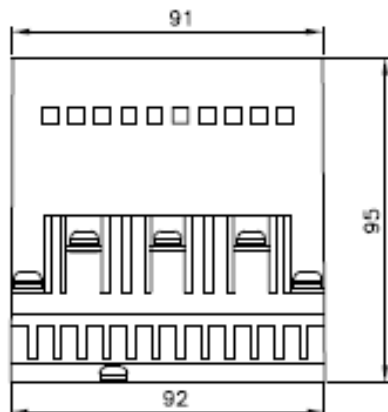

### Frame B

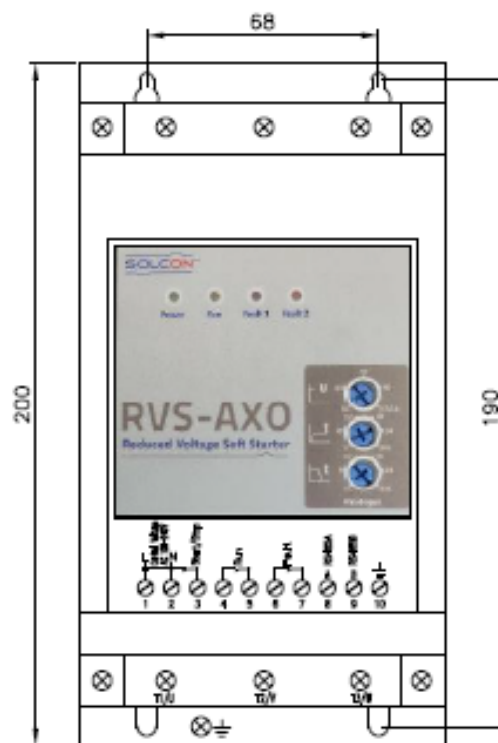
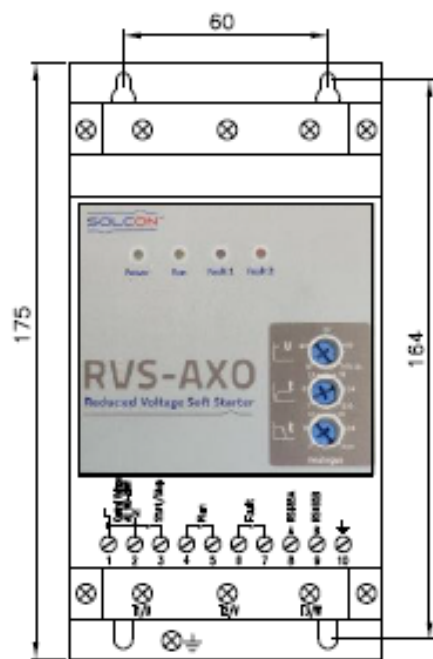
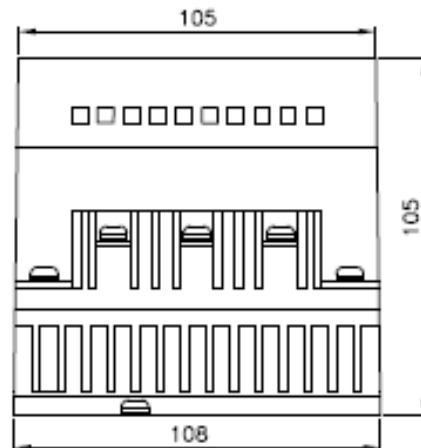

**Frame C**

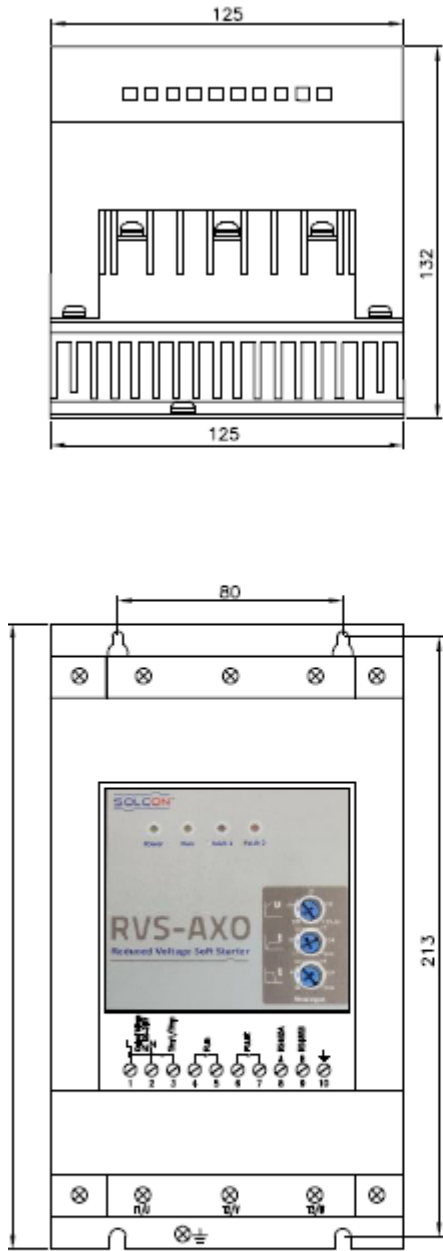

**Frame D**

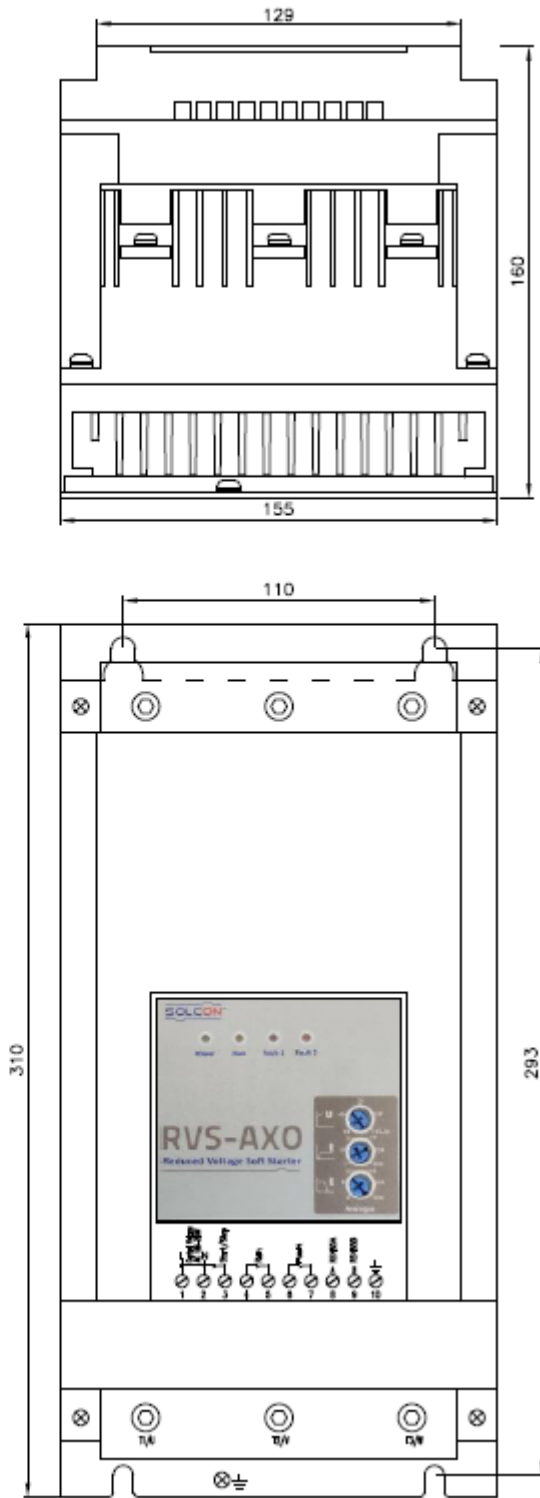

## 6. INSTALLATION

### 6.1 Prior to Installation

Check that Motor's Full Load Ampere (FLA) is lower than, or equal, to the starter's Full Load Current (FLC) and that Mains and Control voltages are as indicated on the starter's side label.

### 6.2 Mounting

The starter must be mounted vertically. Allow sufficient space (at least 100mm) above and below the starter for suitable airflow.

Do not mount the starter near heat sources.

Surrounding air temperature in the cabinet should not exceed 40°C. Protect the starter from dust and corrosive atmospheres.

### 6.3 Power wiring instructions

- Input power and output motor field wiring shall be copper conductors, rated at least 75°C.
- Minimal wire size, terminal screw and torque ratings for attachment to power inputs of RVS-AXO are presented below.

<b>RVS-AXO</b>	<b>Terminals Screw</b>	<b>Minimal wire size (mm<sup>2</sup>)</b>	<b>Mechanical Torque (N*m)</b>
RVS-AXO 3	M5	2.5	3
RVS-AXO 4.5	M5	2.5	3
RVS-AXO 7.5	M5	2.5	3
RVS-AXO 11	M5	2.5	3
RVS-AXO 15	M5	2.5	3
RVS-AXO 22	M5	4	5
RVS-AXO 30	M5	4	5
RVS-AXO 37	M5	6	5
RVS-AXO 45	M6	10	5
RVS-AXO 60	M6	16	5
RVS-AXO 75	M6	16	5
RVS-AXO 90	M8	35	19
RVS-AXO 110	M8	50	19
RVS-AXO 150	M8	50	19

## 7. OPERATION INTERFACE

### 7.1 Control

- Initial voltage at Start and voltage rise (Start) / reduction time (Stop) set by 3 built-in potentiometers or by Modbus communication channel.?
- Start / Stop command supplied by external voltage free contact or by Modbus communication channel.
- Fault reset can be done by switching control voltage OFF / ON or by Modbus communication channel.

### 7.2 Control terminals

#	Name	Duty
1	L	Control voltage (100-240Vac) phase input
2	N	Control voltage neutral input
3	Start / Stop	Connect 100-240Vac related to N to start the motor. Disconnect – to stop the motor.
4	Run relay NO	Closed in Start and Run or only Run state of the starter.
5	Run relay common	
6	Fault relay NO	Closed in Fault state of the starter.
7	Fault relay common	
8	RS485 A-Line (+)	RS485, Modbus communication port.
9	RS485 B-Line (-)	
10	Ground	

### 7.3 User interface and LEDs status description

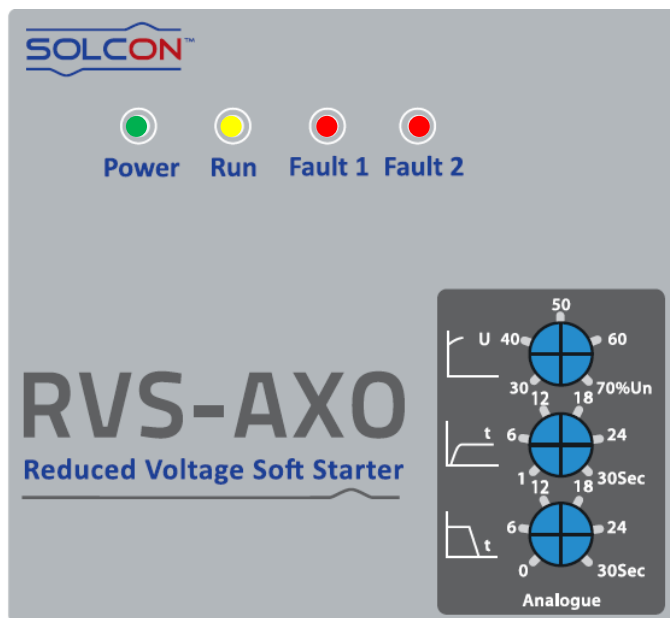

#### Potentiometer's Duty

Set initial voltage to 30-70%.

Set voltage rise time to 1-30 sec.

Set voltage ramp down time to 0-30 sec.

### 7.4 LEDs status description

LED	Duty
Power (green)	When the soft starter is power on, the power supply LED is ON.
Run (yellow)	When the soft starter stops, running LED is OFF.
	When soft starter soft starts / soft stops state, running LED is blinking.
	When the soft starter is in bypass state, running LED is ON.
Fault 1 (red)	When the soft starter is in fault state, the fault LED blinks or ON.
Fault 2 (red)	

Fault	LED Fault 1	LED Fault 2
Wrong phase sequence	Blinks	
Phase loss / No voltage		Blinks
Max Start Time	Blinks	Blinks
Over current		Lights
Overload	Lights	Blinks
Current unbalance	Lights	
Over Temperature	Blinks	Lights



## 7.5 Trouble shooting

Fault	Fault 1	Fault 2	Fault reason	Solution
Phase sequence trip	○	○	The sequence of three phase voltage is wrong	Change the sequence of three phase.
Missing phase trip/No voltage trip	○	○	Missing one phase or two phase voltage in three phase voltage /NO voltage input	The connection between the soft start and the main power supply is open.
Over current trip	○	●	Current value exceeding over current setting value	Check whether the connection between soft start and motor is short circuited.
Over load trip	●	○	Current value exceeds overloading set value	Check whether the motor overloaded or AXO overload settings are incorrect.
Unbalanced current trip	●	○	The unbalanced three-phase current is larger than the unbalanced current setting value	Check the winding of the motor and the connection between soft starter and motor.
Over temp trip	○	●	The temperature of the heatsink exceeds 75°C	Check if too many starts or the selection of soft starter model is too small.
Under current trip	●	●	Current value lower than under current set value during bypass	Check whether the load is too small like pump dry burning
Max start time trip	○	○	The time of starting process exceeds the max start time value	Try to reduce voltage ramp or/and increase current limit.

◎ Blink;      ● On;      ○ OFF

## 8. PROTECTION SETTINGS

### 8.1 Protections list

Fault	Active at				Setting range	Factory set
	Stop	Start	Soft Stop	Bypass		
Wrong phase sequence	x	v	v	v	Enabled / Disabled	Enabled
Phase loss / No voltage	x	v	v	v		
Max Start Time	x	v	x	x	0 – 35Sec.	30sec
Over current instantaneous	v	v	v	v	850% FLA	850% FLA
Over current delayed	v	v	v	v	200-600% FLA with delay 0.1-1Sec.	450%, 1sec
Overload	x	x	x	v	Pickup 100-200% FLA, Class 10A, 10, 20, 30	115%, 10A
Unbalance	x	x	x	v	10-50% of FLA, 0 – 25Sec delay	30%, 10sec
Over Temperature	v	v	v	v	80°C (heat sink temperature)	80°C

**Note:**

Factory settings can be changed by Modbus communication channel.

## 8.2 Overload trip time

Overload trip delay depends on motor initial state (cold / hot), motor current, selected overload protection class and selected overload protection pickup.

Delays for hot motor and selected pickup = 115% FLA are presented below.

### Electronic overload and tripping curve

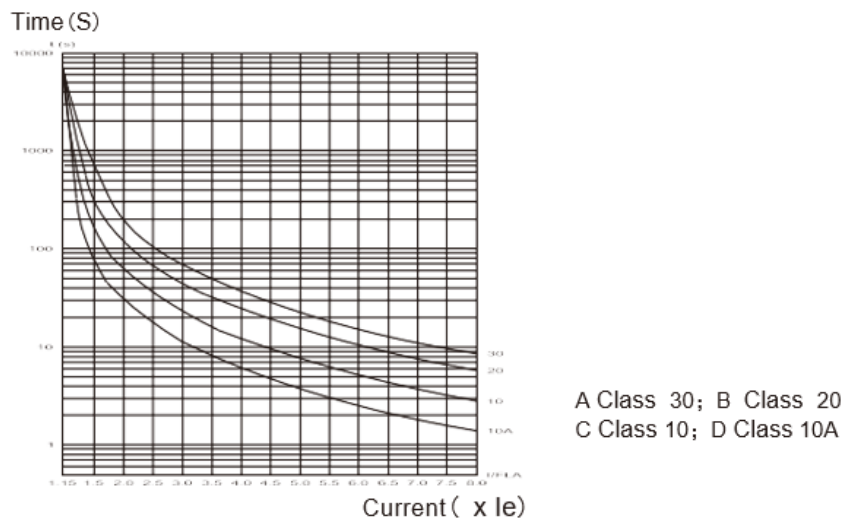

Overload class	Motor current %FLA						
	800	700	600	500	400	300	200
10A	1.6sec	2sec	3sec	4sec	6sec	12sec	26sec
10	3	4	6	8	13	23	52
20	5	6	9	12	19	35	78
30	7	9	13	19	29	52	112

## 9. SETTING PARAMETERS

Those parameters can be changed by Modbus communication channel.

<b>Parameter</b>	<b>Setting range</b>	<b>Factory setting</b>
Motor FLA	1-150A	According to RVS-AXO model
Start parameters setting	0 – by potentiometers 1 – by Modbus channel	0
Initial Voltage at Start	1 – 15 (1 ->30%, 15 ->70%)	Applicable when [Start parameters setting] set to Modbus channel
Voltage rise time at Start	1 – 15 (1 ->1Sec, 15 ->30Sec)	
Voltage reduction time at stop	1 – 15 (1 ->0Sec, 15 ->30Sec)	
Current Limit	300- 500 % FLA	340%
Max Start Time	0-35 Sec.	30 Sec.
Over current trip level	200-600% FLA	450%
Over current trip delay	0 – 2 sec	1 sec
Overload protection pickup	100 – 200% FLA	115%
Overload protection level	0 – 10A 1 – 10 2 – 20 3 - 30	10A
Phase sequence protection	0– OFF 1- ON	ON
Modbus Address	1 - 127	1
Baud Rate	0 - 1200 1 – 2400 2 – 4800 3 – 9600 4 - 19200	9600
Parity check	0 – Even 1 – Odd 2 - None	Even

## 10. SERIAL LINK PROTOCOL INTRODUCTION

This document summarizes the serial link protocol to / from the DIGITAL SOFT STARTER (RVS-AXO).

### 10.1 Features

- \* RS485 Hardware.
- \* Asynchronous serial link.
- \* Half duplex.
- \* Format: **Modbus RTU Mode** (Remote Terminal Unit Mode).
  - Binary,
  - Each character includes 11 bits:
    - 1 start bit
    - 8 data bits, least significant bit sent first.
    - 1 Parity bit. Even / Odd / No can be selected..
    - 1 Stop bit if Parity is used, 2 stop bits if Parity is not used.
  - Cyclical Redundancy Check (CRC), 16 bits.
- \* Baud Rates: 1200/2400/4800 / 9600/19200 bits per second..
- \* Response time of the RVS-AXO:
  - Normally, 4ms <= time response <= 40mS.
  - For a long response, time response <= 200mS.
- \* It is not recommended to transmit to the RVS-AXO too often, at a faster rate than once per second, as it can slow down RVS-AXO time delays.
- \* After storing setting parameters, it is forbidden to transmit again to the same RVS-AXO in less than 1 sec.
- \* Broadcast commands: not supported.

#### Notes:

\* **It is a must to connect earth to the RVS-AXO earth terminal before connecting serial link wires. Ignoring this instruction may result in permanent damage to the Serial Link Hardware.**

\* **Being in Start / Soft Stop state RVS-AXO is busy controlling its SCRs and communication will not respond to requests.**

- \* It is recommended to connect 120 Ohm resistors on both ends of the serial link.
- \* Turn off (and on again) control power after changing Baud Rate, Parity Check or Serial Link No (Slave Address).

## 10.2 BASIC STRUCTURE OF THE SERIAL LINK FRAME

Modbus RTU frame have the same principal structure for both the "Query" transmission from the Masterto the Slave (RVS-AXO) and the Response transmission from the Slave to the Master.

"Sync": Silent time of at least 3.5 character (3.5 \* 11 bit times).  
 Byte 1: Serial Link No. (= Slave Address) (1...147)  
 Byte 2: Function (1, 2, 3,4,5,6,8,15 &16 are supported)  
 Byte 3: Data Bytes (\$XX)  
 : : (\$XX)  
 : : (\$XX)  
 Byte n-1: CRC\_Low (\$XX)  
 Byte n: CRC\_High (\$XX)  
 "Sync": Silent time of at least 3.5 character (3.5 \* 11 bit times).

## 10.3 SYNC (Silent Interval)

In RTU mode messages "synchronize" by a "Silent Interval" of more than 3.5 character times. This silent interval separates between transmission frames.

The entire frame must be transmitted as a continuous stream. A silent time of more than 3.5 character times during frame transmission will cause the receiving device to ignore the incomplete frame. Next byte will be assumed as the Serial Link No. of the next frame.

Same result of ignoring the frame can occur if a second message is transmitted before 3.5 character times from the end of the previous one. This will cause the receiving device to consider it as a continuation of the first frame, resulting with CRC error.

## 10.4 SERIAL LINK NO. (SLAVE ADDRESS)

Contains RVS-AXO Slave Number (1-127) on the serial link. The RVS-AXO default value is 1. Serial LinkNo. is used as the first byte in both the "Query" transmission from Master to Slave and in Response transmission from Slave to Master.

## 10.5 FUNCTION

The Function code informs the RVS-AXO what is the requested action to take. In normal cases, Function is used as the second byte in both the "Query" transmission from Master to Slave and in Response transmission from Slave to Master.

## 10.6 LIST OF FUNCTIONS SUPPORTED BY THE RVS-AXO

Function	Modbus Name	Use in RVS-AXO
01	Read Coil Status	Read Discrete Commands status.
02	Read Input Status	Read Discrete Inputs status.
03	Read Holding Registers.	Read Setting Parameters.
04	Read Input Registers.	Read actual data.
05	Force Single Coil.	Force one discrete command.
06	Preset Single Register.	Write one setting parameter.
08	Diagnostics.	Loopback Diagnostics.
15	Force Multiple Coils.	Force Discrete Commands.
16	Force Multiple Registers	Write Setting ParametersControl Commands

## 10.7 DATA

Data field includes information transferred to and from the RVS-AXO. The specific data format is changed with Function. When Word data parameters are transmitted, High Byte is transmitted first, followed by the Low Byte.

## 10.8 CRC

The CRC (Cyclic Redundancy Check) two bytes (16 bit) are used to check the entire frame bytes.

It is generated in the master device and transmitted as the last two bytes of the frame (Low byte is appended first followed by the High byte). The slave device generates the CRC bytes again and compares it to the received CRC bytes. If the CRC bytes are not identical, the frame is flushed and no response is transmitted to the master.

## 10.9 ACTUAL DATA (Input registers)

Actual data includes measured values such as currents and mains frequency. It includes also logic information as well as statistical information. All parameters are **word** (two bytes) parameters. The protocol supports only Reading of these parameters.

Address	Register	Range / Unit	Note
0	Phase L1 current	%FLA	
1	Phase L2 current	%FLA	
2	Phase L3 current	%FLA	
3	Initial Voltage	0...512 (0~70%, 512~30%)	Represent potentiometers state.
4	Voltage rise time at start	0..512 (0~30, 512~1 Sec)	
5	Voltage reduction time	0...512(0~30,512~0 Sec)	
6	Average current	%FLA	
7	Mains Frequency	Hz	
8	RVX-AXO status	1~Stop, 129~Fault,	
9	Hardwire inputs	0~ Start / Stop open, 1~ Start / Stop closed	
10	Fault status	Code-2 of active fault. See faults list below.	
11	Accumulated running time	Hours	
12	Accumulated running time	Tenth of a second.	
13	Number of starts		
14	Number of faults		
15	Reserved		
16-25	Code-1 of 10 last faults.		
29	Software version	1	
30	Software version	6	
31	Software version	32/33	32 : for 3-22A units 33 : for 30-150A units



## 10.10 Faults list

Fault	Code-1	Code-2	
Over temperature	1	1	
Phase loss/ no voltage	2	2	
Over current	3	4	
Over load	4	8	
Current unbalance	5	16	
Negative phase sequence	6	32	

### Example 1

To read input registers at addresses 0...2 (Phase currents I1, I2, I3) of RVS-AXO # 18 the host computer should send following frame:

Byte 1:	Serial Link No.	(\$12)
Byte 2:	Function	(\$04)
Byte 3:	Starting Address High	(\$00)
Byte 4:	Starting Address Low	(\$00)
Byte 5:	No. of Points High	(\$00)
Byte 6:	No. of Points Low	(\$03)
Byte 7:	CRC_Low	(\$XX)
Byte 8:	CRC_High	(\$XX)

The RVS-AXO response, when Current = 80, 81, 82 % FLA, is:

Byte 1:	Serial Link No.	(\$12)
Byte 2:	Function	(\$04)
Byte 3:	Byte Count	(\$06)
Byte 4:	Data High, I1	(\$00)
Byte 5:	Data Low, I1	(\$50)
Byte 4:	Data High, I2	(\$00)
Byte 5:	Data Low, I2	(\$51)
Byte 6:	Data High, I3	(\$00)
Byte 7:	Data Low, I3	(\$52)
Byte 8:	CRC_Low	(\$XX)
Byte 9:	CRC_High	(\$XX)

**Note:** \$XX indicates Hexadecimal byte.

## 10.11 SETTING PARAMETERS (Holding registers)

All parameters are word (two bytes) parameters. The protocol supports Reading with function 3 and modifying these parameters with functions 6, 16.

**Any one of these parameters must be set with care. Harmful results can occur both to motor and RVS-AXO by incorrect settings of some parameters.**

Address	Register	Range / Unit	Factory setting
0	RVS-AXO FLC	3...150A	According to AXO model
1	Motor FLA	3...150A	According to AXO model
2	Reserved		
3	Reserved		
4	O/C protection level	200...600%FLA	450%
5	O/C protection delay	0..20 tenth second	10 (0.1sec)
6	O/L protection pickup	100...200%FLA	115%
7	O/L protection class	0-class10A 1-class10 2-class 20 3-class 30	0-class10A
8	U/C protection level	0...100% FLA	0%
9	U/C protection delay	0...600 (*.1 sec)	600 (60 sec.)
10	Unbalance protection level	10...50%FLA	30%
11	Unbalance protection delay	0...250 (*.1 sec)	100 (10 sec)
12	Reserved		
13	Phase sequence protection	0-disabled 1-enabled	0
14	Reserved		
15	Reserved		
16	Initial Voltage	0...15 (30...70%)	See parameter 20

17	Voltage rise time at Start (acceleration time)	0...15 (1...30 sec)	Effective only when register @20 set to 1 / Modbus control. Otherwise potentiometers position define start / stop program.
18	Voltage reduction time at stop (deceleration time)	0...15 (0...30 sec)	
19	Current Limit level	300...500% FLA	340%
20	Parameters setting	0 – potentiometer setting 1 – Modbus setting	0 – potentiometer setting
21	Max Start Time	0...350 (*.1 sec)	300 (30sec)
22...31	Reserved		
32	Run relay type (contacts 4,5)	0 – immediate (energized during start, run, soft stop) 1 – bypass status	0
33	Bypass mode	0-continue firing pulses after closing bypass 1-stop continue firing pulses after closing bypass	0
34, 35	Reserved		
36	Slave Address	1...127	
37	Baud Rate	0-1200 1-2400 2-4800 3-9600 4-19200	3-9600
38	Parity	0-EVEN 1-ODD 2- NONE	0-EVEN
39	<b>End_of_acceleration</b> (If oscillations appear near full speed , try to increase the parameter value)	120...300 (%FLA)	160
40	<b>Ratio_to_peak</b> If oscillations appear near full speed , try to increase the parameter value	3...9 (*0.1 Maximum current during starting)	6
41	<b>Current to close bypass</b> (close bypass when current drops down below this level)	120...300 (%FLA)	120

---

42	<b>Initial firing angle at the beginning of Soft Stop</b> (increase this value if oscillations appear at the beginning of the soft stop) For heavily loaded motor ,if voltage drops too much at the beginning of soft stop, decrease this parameter.	0...12 (* 5 degree)	6
43	<b>Stop Mode</b> '0' - Stop directly when oscillations have been detected .  '1' - Speed up when oscillations have been detected  Change to '0' if oscillations cannot be eliminated by parameter 42.	0...1	1
44	<b>Initial Dec Time</b> (Determines the time for change of firing angle to value set in parameter 42)	0...20 (*0.1sec)	5

**Example 2:**

To Read holding registers at addresses 4 and 5 (O/C protection level, delay) of RVS-AXO # 18, the host computer should send following frame:

Byte 1:	Serial Link No.	(\$12)
Byte 2:	Function	(\$03)
Byte 3:	Starting Address High	(\$00)
Byte 4:	Starting Address Low	(\$04)
Byte 5:	No. of Registers High	(\$00)
Byte 6:	No. of Registers Low	(\$02)
Byte 7:	CRC_Low	(\$XX)
Byte 8:	CRC_High	(\$XX)

The RVS-AXO normal response:

Byte 1:	Serial Link No.	(\$12)	
Byte 2:	Function	(\$03)	
Byte 3:	Byte Count	(\$04)	
Byte 4:	Data High	(\$01)	(O/C Protection Level = 500%)
Byte 5:	Data Low	(\$F4)	
Byte 6:	Data High	(\$00)	(O/C Protection Delay = 0.1Sec)
Byte 7:	Data Low	(\$01)	
Byte 10:	CRC_Low	(\$XX)	
Byte 11:	CRC_High	(\$XX)	

**Example 3:**

To set one holding register at address 4 (O/C protection level) to 600 (%FLA) of RVS-AXO# 18, the host computer should send following frame:

Byte 1:	Serial Link No.	(\$12)	
Byte 2:	Function	(\$06)	
Byte 3:	Starting Address High	(\$00)	
Byte 4:	Starting Address Low	(\$04)	
Byte 5:	Preset Data High	(\$02)	(600)
Byte 6:	Preset Data Low	(\$58)	
Byte 7:	CRC_Low	(\$XX)	
Byte 8:	CRC_High	(\$XX)	

The RVS-AXO normal response, is an echo of the query:

Byte 1:	Serial Link No.	(\$12)
Byte 2:	Function	(\$06)
Byte 3:	Starting Address High	(\$00)
Byte 4:	Starting Address Low	(\$04)
Byte 5:	Preset Data High	(\$02)
Byte 6:	Preset Data Low	(\$58)
Byte 7:	CRC_Low	(\$XX)
Byte 8:	CRC_High	(\$XX)

#### Example 4:

To set two holding registers (O/L protection pickup = 120%, O/L protection class = 30) of RVS-AXO # 18, the host computer should send following frame:

Byte 1:	Serial Link No.	(\$12)	
Byte 2:	Function	(\$10)	
Byte 3:	Starting Address High	(\$00)	
Byte 4:	Starting Address Low	(\$06)	
Byte 5:	No. Of Registers High	(\$00)	
Byte 6:	No. Of Registers Low	(\$02)	
Byte 7:	Byte Count	(\$04)	
Byte 8:	Data High	(\$00)	(120)
Byte 9:	Data Low	(\$78)	
Byte 10:	Data High	(\$00)	
Byte 11:	Data Low	(\$03)	
Byte 16:	CRC_Low	(\$XX)	
Byte 17:	CRC_High	(\$XX)	

The RVS-AXO normal response:

Byte 1:	Serial Link No.	(\$12)
Byte 2:	Function	(\$10)
Byte 3:	Starting Address High	(\$00)
Byte 4:	Starting Address Low	(\$06)
Byte 5:	No. Of Registers High	(\$00)
Byte 6:	No. Of Registers Low	(\$02)
Byte 7:	Crc_Low	(\$Xx)
Byte 8:	Crc_High	(\$Xx)

## 10.12 DISCRETE COMMANDS (@0...@7 coils)

The RVS-AXO incorporates 8 "Coils", (bit parameters).

Address	Coil	Usage
0	Start / Stop	1 – Start, 0 - Stop
1	Reserved	
2	Reserved	
3	Reserved	
4	Reserved	
5	Reserved	
6	Reserved	
7	Reset	1 – Reset.

### Example 5 - Force Single Coil:

To start the motor controlled by RVS-AXO # 18, the host computer should write "1" to the Start / Stop coil.

Note: For Force Single Coil Function, Force Data of \$0000 forces "0" = OFF. Force data of \$FF00 forces "1" = ON. The "Query" frame sent by the host:

Byte 1:	Serial Link No.	(\$12)	
Byte 2:	Function	(\$05)	
Byte 3:	Coil Address High	(\$00)	
Byte 4:	Coils Address Low	(\$00)	
Byte 5:	Force Data High	(\$FF)	(Force ON)
Byte 6:	Force Data Low	(\$00)	
Byte 7:	CRC_Low	(\$XX)	
Byte 8:	CRC_High	(\$XX)	

The normal (if no exception) response:

Byte 1:	Serial Link No.	(\$12)
Byte 2:	Function	(\$05)
Byte 3:	Coil Address High	(\$00)
Byte 4:	Coils Address Low	(\$01)
Byte 5:	Force Data High	(\$FF)
Byte 6:	Force Data Low	(\$00)
Byte 7:	CRC_Low	(\$XX)
Byte 8:	CRC_High	(\$XX)

### 10.13 DISCRETE HARDWIRED INPUTS Reading

The RVS-AXO incorporates 8 Discrete Inputs, (bit parameters).

Address	Input	Usage
0	Start / Stop	1 – Closed, 0 - Open
1	Reserved	
2	Reserved	
3	Reserved	
4	Reserved	
5	Reserved	
6	Reserved	
7	Reserved	

#### Example 6:

To read Start / stop input status the host computer should send following Query frame:

Byte 1:	Serial Link No.	(\$12)
Byte 2:	Function	(\$02)
Byte 3:	Starting Address High	(\$00)
Byte 4:	Starting Address Low	(\$00)
Byte 5:	No. of Points High	(\$00)
Byte 6:	No. of Points Low	(\$01)
Byte 7:	CRC_Low	(\$XX)
Byte 8:	CRC_High	(\$XX)

The RVS-AXO response, when Start/Stop input is closed:

Byte 1:	Serial Link No.	(\$0C)	(12)
Byte 2:	Function	(\$02)	
Byte 3:	Byte Count	(\$01)	
Byte 4:	Data	(\$01)	(Start / Stop Input Is Active)
Byte 5:	CRC_Low	(\$XX)	
Byte 6:	CRC_High	(\$XX)	



## 10.14     **DIAGNOSTICS**

Modbus Function 08, as implemented in the RVS-AXO supports only Sub-function \$0000. It provides for "loopback" (Return Query Data) feature, for checking the CommunicationSerial Link between the master and the RVS-AXO.

To request RVS-AXO # 18 to return Query data, the master should send following Query frame:

Byte 1:	Serial Link No.	(\$01)
Byte 2:	Function	(\$08)
Byte 3:	Sub-function High	(\$00)
Byte 4:	Sub-function Low	(\$00)
Byte 5:	Data High	(\$A5)
Byte 6:	Data Low	(\$37)
Byte 7:	CRC_Low	(\$XX)
Byte 8:	CRC_High	(\$XX)

The normal (if no exception) response is the echo of the Query:

Byte 1:	Serial Link No.	(\$12)
Byte 2:	Function	(\$08)
Byte 3:	Sub-function High	(\$00)
Byte 4:	Sub-function Low	(\$00)
Byte 5:	Force Data High	(\$A5)
Byte 6:	Force Data Low	(\$37)
Byte 7:	CRC_Low	(\$XX)
Byte 8:	CRC_High	(\$XX)

## 10.15 EXCEPTION RESPONSES

When the master sends a query frame to an RVS-AXO, one of the following four responses from the RVS-AXO is possible:

1. When no communication error is detected in the query, and no mistake is found by the communication program module in the RVS-AXO, a normal response is returned.
2. If the RVS-AXO does not receive the query frame (for example because of disconnected serial link cable) then no response is returned by the RVS-AXO. After proper time the master will cause a timeout condition.
3. If the RVS-AXO receives the query, but a faulty CRC bytes and / or Parity bits are detected, then no response is returned by the RVS-AXO. After proper time the master will cause a timeout condition.
4. If no communication error is detected in the query, but the RVS-AXO communication program module finds an error such as illegal Function, data address or data value, or if the RVS-AXO is busy, then an Exception response is returned. The Exception response includes Exception Code to inform the master about the type of the error.

## 10.16 Exception Code Response Frame

Exception response frame holds fix number of 5 bytes. The first one, the Slave Address field is the Serial link number (transmitted in query and identical to RVS-AXO Serial Link No.). The second byte, the Function field returns the echo of the transmitted query function, but with the Most Significant Bit set to 1 (adding \$80 to the transmitted function code). The third byte is the Exception Code informing about the type of error. Last two bytes are the CRC bytes.

## 10.17 Exception Codes supported by the RVS-AXO

Exception Code	Type	Comment
01	Illegal Function	Requested Function is not supported. Functions 1..6, 8, 15 or 16 are supported.
02	Illegal Data Address	Data address is not allowable.
03	Illegal Data Value	Data Value is not in allowable range.
06	RVS-AXO Busy	RVS-AXO is busy now. The master should transmit the message again later.

### Example 10:

Master is trying to force coil # 17 of RVS-AXO 32. The RVS-AXO incorporates only 16 coils. Illegal Data Address Exception code will be returned:

Query:

Byte 1:	Serial Link No.	(\$20)	(32)
Byte 2:	Function	(\$05)	
Byte 3:	Coil Address High	(\$00)	
Byte 4:	Coils Address Low	(\$11)	(17, Non Existent Coil)
Byte 5:	Force Data High	(\$00)	(\$0000 = "0" = Low)
Byte 6:	Force Data Low	(\$00)	
Byte 7:	CRC_Low	(\$XX)	
Byte 8:	CRC_High	(\$XX)	

Exception response:

Byte 1:	Serial Link No.	(\$20)	
Byte 2:	Function	(\$85)	(Original + \$80)
Byte 3:	Exception Code	(\$02)	(Illegal Data Address)
Byte 4:	CRC_Low	(\$XX)	
Byte 5:	CRC_High	(\$XX)	

**Note:**

There are cases where the RVS-AXO returns Normal response, but the requested action cannot be performed, or is modified by the RVS-AXO. Few examples are:

<b>Requested Action</b>	<b>Performed Action</b>
Writing Setting parameters during start process	Ignored
Writing few parameters (Function 16), some are out of range	Limiting to allowed range
Start command (Function 05) while Stop Hardwired Input is open	Command ignored

It is the user responsibility to verify that the requested action was performed, by reading the value of the modified parameters or the status of the command Coils.



**Solcon Industries Ltd.**

<http://www.solcon.com> , [office@solcon.com](mailto:office@solcon.com)